

BG 20

Art. No. 3020

20 cm (8") full-range speaker with tweeter dome. High efficiency. Suitable for full-range units as vocal or guitar monitors or as a mid-range unit for full-scale or musicians' PA systems.

Typical applications:

- Midrange unit for full scale or musicians' PA systems
- Vocal or guitar monitors
- Fullrange speaker for electronic organs and keyboards

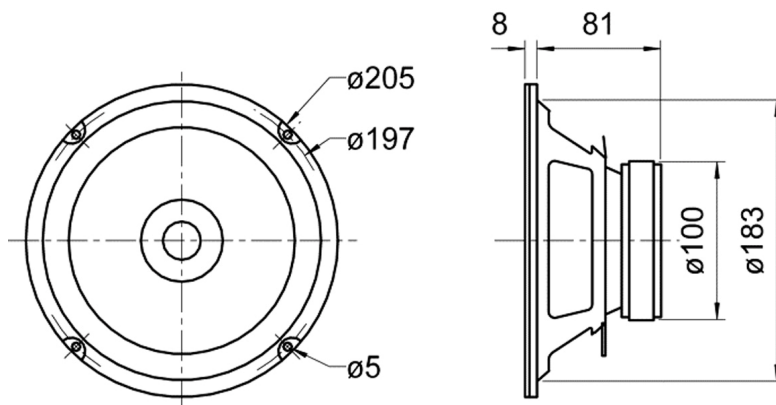

BG 20
27.07.1999



Technical Data:

Rated power	40 W
Maximum power	70 W
Nominal impedance Z.....	8 Ohm
Frequency response	fu-18000 Hz
(fu: Lower cut-off frequency depending on cabinet)	
Mean sound pressure level	92 dB (1 W/1 m)
Opening angle (-6 dB)	45°/4000 Hz
Excursion limit.....	+/-4 mm
Resonance frequency fs.....	38 Hz
Magnetic induction.....	1,2 T
Magnetic flux.....	380 μ Wb
Height of front pole-plate	4 mm
Voice coil diameter	25 mm
Height of winding	8 mm
Cutout diameter	184 mm
Net weight.....	1,3 kg
D.C. resistance Rdc.....	6,2 Ohm
Mechanical Q factor Qms	3,47
Electrical Q factor Qes.....	0,51
Total Q factor Qts	0,44
Equivalent volume Vas	110 l
Effective piston area Sd.....	214 cm ²
Dynamically moved mass Mms	10 g
Force factor Bxl.....	6,1 Tm
Inductance of the voice coil L.....	0,8 mH
Temperature range.....	-25 ... 70 °C

Visaton BG 20 - 8 Ohm

Frequenzgang und Impedanz

